

SUBMITTAL SHEET

WALLS ONLY

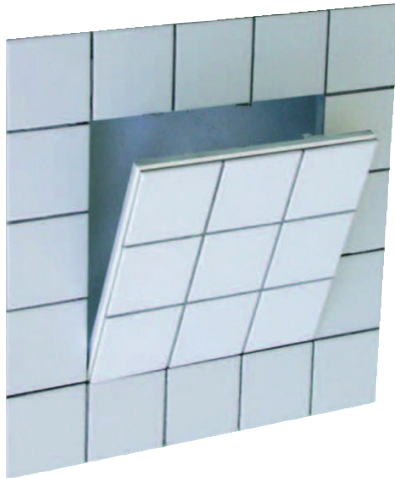

Installed door – virtually invisible



Felt gasket surrounds perimeter of door to help provide air & temperature control



Heavy duty reinforced plastic corners ensures flush installation

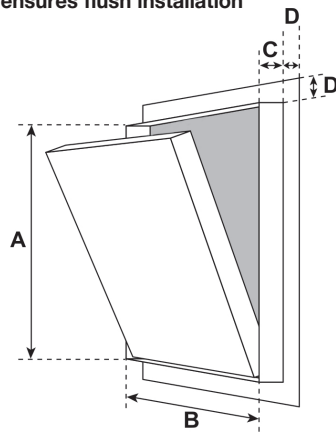

SECTION DETAIL



REMOVABLE PLASTIC SAFETY CATCH

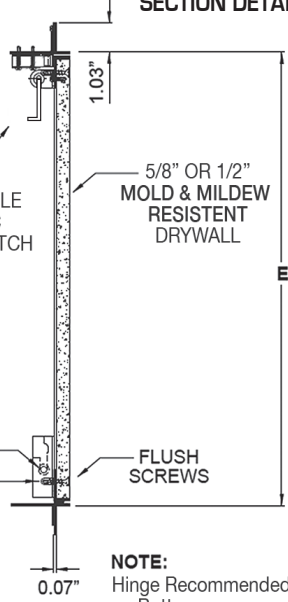

NOTE:
 Hinge Recommended on Bottom

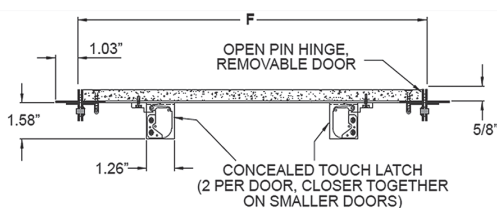

The **WB DWAL 414-HD** access door/panel is a recessed access door with touch latches for a tile application. This recessed access panel for tile applications is perfect for environments where there will be a tile finish such as hospitals, bathrooms, locker rooms, or hotels. With a touch latch mechanism, this door avoids the use of any visible latches; therefore, the tile sits flush inside the access doors recess. This recessed touch latch access door/panel is available with 5/8" or 1/2" recess depending on the depth of the tile used. The **WB DWAL 414-HD** recessed access door for tile is proudly manufactured for **The Williams Brothers Corporation of America**.

SPECIFICATIONS:

Door & Frame: Lightweight Welded Aluminum with reinforced plastic corners

Removable Door: Fully Detachable Hatch/Door

Finish: Recessed 5/8" or 1/2" for Tile

Latches: Heavy Duty Concealed Touch Latches

Hinges: Concealed Hinge with fully removable door

Gasket: Felt gasket surrounds the perimeter of the door to provide air & temperature control

Standard Features:

- Fast shipping with large inventory
- Easy assembly & clean install
- Solid aluminium frame with reinforced plastic corners
- Flush installation in walls
- Moisture & mildew resistant drywall
- Felt gasket installed on all 4 sides
- Virtually invisible when installed

OPTIONS (AT ADDITIONAL COST)

- Custom sizes available
- WB Key Cylinder Locks - keyed alike 2 keys per door
-

✓	Model No.	Door Size	Cut Opening	Ship Wt. Lbs.
	DWAL 414-HD	8 x 8	8 3/8 x 8 3/8	5
	DWAL 414-HD	10 x 10	10 3/8 x 10 3/8	7
	DWAL 414-HD	12 x 12	12 3/8 x 12 3/8	8
	DWAL 414-HD	14 x 14	14 3/8 x 14 3/8	13
	DWAL 414-HD	16 x 16	16 3/8 x 16 3/8	15
	DWAL 414-HD	18 x 18	18 3/8 x 18 3/8	17
	DWAL 414-HD	20 x 20	20 3/8 x 20 3/8	20
	DWAL 414-HD	24 x 24	24 3/8 x 24 3/8	24
	DWAL 414-HD	24 x 36	24 3/8 x 36 3/8	35

Custom sizes available upon request.

RELATED PRODUCTS

WB DW 400 Series for Drywall



Project: _____ Date: _____
 Contractor: _____ Architect: _____
 Sizes: _____ Quantity: _____ App Initials: _____

1330 Progress Drive • Front Royal, VA 22630 • Phone: 1-800-255-5515 • www.wbdoors.com



The World's Largest Access Door Store.™

