

**SUBMITTAL SHEET**

**CEILING ONLY**

Patent Pending.  
 Invented by Gabriel Williams



SEALED DRYWALL EDGES CORNER DETAIL

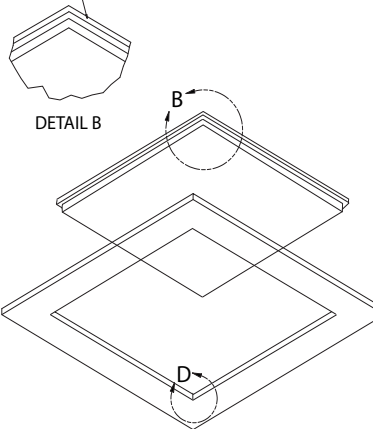

**SPECIFICATIONS:**

Patent Pending.

The **WB DW 405 Phantom™ Series** Drywall Ceiling Access Panel is a cost-effective, durable flush access panel for ceiling installation that is perfect for applications where a concealed appearance is required such as high luxury properties including hotels, apartment complexes, educational facilities, lobbies, and government buildings. Featuring lightweight, Type X fire and impact resistant gypsum board (drywall) construction. making them an excellent choice for use in residential and commercial bathrooms, locker rooms, showers, and more.

**Door & Trim:** 5/8" Frame and 1 inch thick door. Type X fire resistant drywall gypsum, moisture, mold, and mildew resistant.

**Finish:** Composed of 100% recycled PURPLE paper on the face and back side. Completely paintable.

**Meets and exceeds specs of GFRG access doors.**

**Physical Properties:**

- Entirely of drywall
- Impact resistant
- Cost effective
- Sealed edges for durability
- Moisture free and ready to match existing ceiling
- Made in Virginia - USA

**OPTIONS (at additional cost)**

- Custom sizes available - fast
- Gasketing

✓	Model No.	Door Opening	Rough Opening	Ship Wt. Lbs.
	DW 405 SQ Phantom	6 x 6	12 x 12	1.5
	DW 405 SQ Phantom	8 x 8	14 x 14	2.5
	DW 405 SQ Phantom	9 x 9	15 x 15	3
	DW 405 SQ Phantom	10 x 10	16 x 16	3.5
	DW 405 SQ Phantom	12 x 12	18 x 18	5
	DW 405 SQ Phantom	12 x 16	18 x 20	6
	DW 405 SQ Phantom	12 x 18	18 x 24	7
	DW 405 SQ Phantom	12 x 24	18 x 30	7.5
	DW 405 SQ Phantom	14 x 14	20 x 20	8
	DW 405 SQ Phantom	14 x 20	20 x 26	8.5
	DW 405 SQ Phantom	14 x 24	20 x 30	9
	DW 405 SQ Phantom	16 x 16	22 x 22	9.5
	DW 405 SQ Phantom	16 x 20	22 x 26	9.75
	DW 405 SQ Phantom	16 x 24	22 x 30	10
	DW 405 SQ Phantom	18 x 18	24 x 24	11
	DW 405 SQ Phantom	18 x 20	24 x 26	11.5
	DW 405 SQ Phantom	18 x 24	24 x 30	12
	DW 405 SQ Phantom	20 x 20	26 x 26	12
	DW 405 SQ Phantom	20 x 24	26 x 30	12.5
	DW 405 SQ Phantom	22 x 22	28 x 28	13
	DW 405 SQ Phantom	22 x 24	28 x 30	13.5
	DW 405 SQ Phantom	24 x 24*	30 x 30	14

\* Sizes above 24 x 24 are made with acrylic support.

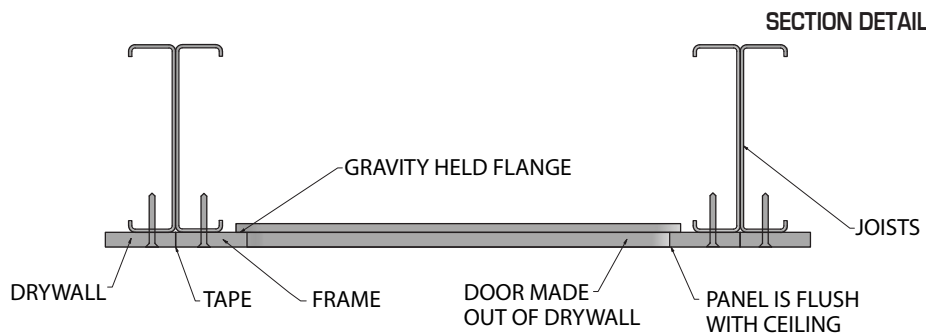

The WB Phantom™ Series is made out of type X fire resistant drywall gypsum board that is moisture, mold, and mildew resistant. Aesthetically invisible in the ceiling.

Project: \_\_\_\_\_ Date: \_\_\_\_\_  
 Contractor: \_\_\_\_\_ Architect: \_\_\_\_\_  
 Sizes: \_\_\_\_\_ Quantity: \_\_\_\_\_ App Initials: \_\_\_\_\_

1330 Progress Drive • Front Royal, VA 22630 • Phone: 1-800-255-5515 • [www.wbdoors.com](http://www.wbdoors.com)



The World's Largest Access Door Store.™

